

PRODUCTION DETAILS

Exterion Media has a highly experienced and dedicated Production Department committed to offer professional print advice, quotes and information on materials related to all your campaign production.

Advertisers are advised to use Exterion Media Production, where we can ensure that all campaigns are printed on approved materials and to the correct specifications.

If you require expert advice and guidance, please contact the Exterion Media Production Department for a free quote or to place your print with one of our specialist suppliers.

CONTACTS:

Sales [!web-enquiry@exterionmedia.co.uk](mailto:web-enquiry@exterionmedia.co.uk)

Production –

Richard Hunt – Head of Production – 0207 428 2829

Adam Webster – Production Manager – 0207 428 3593

David Utton – Snr Production Exec – 0207 428 3688

EXTERION MEDIA

7th Floor, Lacon London
84 Theobalds Road
Holborn
London WC1X 8NL

Contact details:
The Production Department
Tel: 020 7482 3000

Email: productionartwork@exterionmedia.co.uk

CLIENT PRODUCTION

If you have chosen to provide your own posters, please ensure that the bills are printed on the correct substrates. Please note that any part delivery of the Advertisement Copy or Artwork, delivery in the incorrect format, or delivery not meeting the Production Specification or any of Exterion Media UK Limited's Terms and Conditions, as provided, shall be deemed to be no delivery for the purpose of undertaking or procuring the undertaking of Exterion Media's Production Services.

All posters are to be delivered two (2) weeks prior to in-charge date.

Please also be aware that should bills be delivered late Exterion Media cannot guarantee display and this could affect the fixing of your campaign.

If your printer has any questions please contact the Exterion Media Production Department for details.

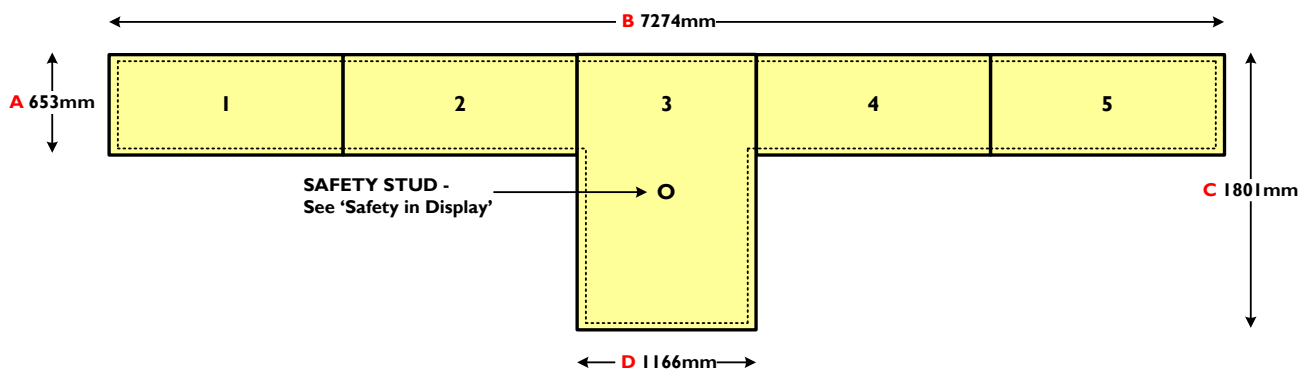

OVERALL SIZE

Sections 1, 2, 4 and 5 measure 653mm deep, 1527mm wide with an additional 12mm **UNPRINTED** overlap on the right-hand edge of sections 1 and 2. Section 4 will require an additional 12mm **UNPRINTED** overlap on both the left and right-hand edges.

----- DISPLAY AREA

A 601mm, B 7222mm, C 1749mm, D 1114mm

Section 3 measures 1801mm deep, 1166mm wide with no overlaps.

Section 3 must be produced in one piece.

EXTERION MEDIA WILL REFUSE TO ACCEPT ANY DELIVERIES THAT DO NOT CONFORM TO THESE SPECIFICATIONS

DELIVERY DEADLINE AND POSTING CYCLE

Posters must be produced to the exact specification set out below and delivered 14 calendar days before the 'In-charge' date of the campaign. Campaigns are then posted on a 6 calendar day cycle (excluding Bank Holidays) which commences before the 'In-charge' date.

Please note: Exterion Media is not liable for compensation claims against any campaign where posters have been received after the delivery deadline. All posters received after the delivery deadline will not be posted until the next available posting cycle for this site type.

QR CODES & NFC TAGS

Exterion Media will not accept QR Codes and NFC Tags on any exterior bus advertising due to Health & Safety concerns.

COPY APPROVAL

Before posting can commence, every Bus campaign must be submitted to Exterion Media for copy approval. This is to ensure that the Codes of Practice outlined by our franchise partners are being upheld. See **Copy Approval** on page 6.

BARCODING

Every campaign must have the appropriate barcode printed on all posters. See **Barcoding of Bus Campaigns** on pages 8 and 9.

SAFETY IN DISPLAY

Because the stem panel in T-Sides can, in some conditions, bow out of shape, we are using a clear, plastic, fixing-stud to ensure safety. The stud measures 6cm in diameter and is positioned in the exact centre of section 3 as indicated in the line drawing.

DISPLAY AREA

For all site types that are fixed into frames, the specification will give the Overall Size and the Display Area. Please keep all important text and images within the Display Area but feel free to bleed the background colours/images up to the Overall Size. Please be aware that if an artwork has text that has been created to the Display Area it will butt-up to the frame. If this is not the desired effect then please move the text even further inside the Display Area.

Please note: Exterion Media strongly recommends that you do not use the frame as a 'cropping device' for corporate logos, as 100% accuracy cannot be guaranteed.

PANEL IDENTIFICATION

Please read the Important Information notice at the start of this specification.

MATERIALS and PRINTING

Please refer to pages 4 and 5 for full details.

EXTERION MEDIA POSTER DESPATCH FORM

The Exterion Media Poster Despatch Form will give all the relevant information for each campaign with regard to quantities, collation details and delivery addresses. If you require a copy, please contact the Exterion Media Customer Service department on 020 7482 3000 and quote the campaign reference.

SPARE POSTERS

Exterior Media will always require additional 'spare' posters to refurbish campaigns. The quantities shown on the Exterior Media Poster Despatch Form will include the required number of spares.

OVERLAPS

The Exterior Media Poster Despatch Form will also indicate which posters are to be delivered 'rolled & collated' and which are to be delivered 'flat & uncollated'. Please remember that all 'rolled & collated' posters will require the appropriate overlaps and all 'flat & uncollated' posters must have the overlaps removed. All overlap information can be found with the line drawing at the beginning of this specification.

PROTECTIVE FINISH

For maximum durability on long-term campaigns, Exterior Media insists a clear machine or UV varnish should be applied to the poster.

TRIMMING

All posters must be trimmed to the exact Overall Size with additional UNPRINTED overlaps where necessary.

POSTER COLLATION AND PACKING

Posters will need to be delivered in a combination of 'rolled & collated' and 'flat & uncollated'.

Rolled & collated: Please collate and roll the 'banner' sections in the following sequence; 1, 2, 4 and 5, with the design out. Then roll the collated 'banner' sections inside section 3, again with the design out. Deliver the posters wrapped in packages of no more than 10, ensuring the edges are fully protected to avoid damage in transit. Folded vinyls cannot be accepted.

Flat & uncollated: Please stack posters flat on a pallet. Section 3 should be placed on the pallet first and a tab must be inserted between every 50th vinyl. Section 5 should then be placed on top of section 3 followed by sections 4, 2 and 1. Again a tab must be inserted between every 50th vinyl and an additional tab inserted indicating the break between each section. The pallet must be bound securely, ensuring the poster edges are fully protected to avoid damage in transit.

POSTER LAYOUTS

A poster layout must be attached to every package or pallet.

QUALITY ASSURANCE DOCUMENTATION

All deliveries will require documentation giving details of Quality Assurance Checks. This must clearly identify the following information: campaign reference(s), print method, ink details and drying method. Exterior Media will also require the name of the person who carried out the Quality Assurance Checks for that particular consignment.

DELIVERY NOTES

Every consignment of posters delivered must have a Delivery Note attached, indicating the following:

- Design name within package
- Overall quantity delivered of each design
- Site type
- Material used
- Date of dispatch
- Time of dispatch
- Printer used
- Printer's telephone number
- Printer's job number
- PDF of design
- Barcode of design

POSTER DELIVERY ADDRESSES

Exterior Media is not responsible for the delivery of your posters. Please contact Exterior Media Customer Service on 020 7482 3000 for the Poster Despatch Form.

CHANGES OF DESIGN

Charges for changes of design are available on request and subject to written agreement from both parties.

Fixing costs are not subject to Agency or Specialist commission.

Exact dates for changes of design are subject to posting cycle workload. Please contact your Account Manager or Exterior Media Customer Service on 020 7482 3000 for more details.

DISPOSAL OF SPARE POSTERS

Please notify Exterior Media Customer Service in writing if you wish to retain spare posters after a campaign has ended. A small storage charge will be made. Otherwise posters will be disposed of 10 days after the campaign has ended. Exterior Media, Lacon House, 84 Theobalds Road, Holborn, London WC1X 8NL.